

EMC TEST REPORT

No. HZ09050492-001

Applicant : Taizhou Jiaojiang Huatai Industry & Trade Co.,Ltd.
No.1 Zhengqian Road, Xiacheng Town,
Jiaojiang ,Taizhou 318010 P. R. China

Manufacturer : Taizhou Jiaojiang Huatai Industry & Trade Co.,Ltd.
No.1 Zhengqian Road, Xiacheng Town,
Jiaojiang ,Taizhou 318010 P. R. China

Equipment : EMC Condensor

Type/Model : KY48C

SUMMARY

The equipment comply with the requirements according to the following standards:

EN55015: 2006/+A1: 2007: Limits and methods of measurement of radio disturbance characteristics of electrical lighting and similar equipment

EN61547: 1995/+A1: 2000: Equipment for general lighting purposed EMC immunity requirements

EN61000-3-2: 2006: Limits for harmonic current emissions (equipment input current ≤ 16 A per phase)

EN61000-3-3: 1995/+A1: 2001/+A2: 2005: Limitation of voltage fluctuations and flicker in low-voltage supply systems for equipment with rated current ≤ 16 A

Date of issue: 2009-06-11

Prepared by:



Leon Xie (*Project engineer*)

Approved by:



Alex Wu (*Reviewer*)

CONTENTS

SUMMARY	1
1.GENERAL INFORMATION.....	5
1.1 Description of Equipment Under Test (EUT)	5
1.2 Description of Client	5
1.3 Description of Test Facility	6
2.TEST SPECIFICATIONS	7
2.1 Standards	7
2.2 Mode of operation during the test.....	7
2.3 Instrument list.....	8
2.4.Test Summary.....	9
Emission Test	10
3. Mains/Load/Control Terminal Continuous Disturbance Voltage	10
3.1 Terminal Voltage Limits for the frequency range 9kHz to 30MHz	10
3.1.1 Disturbance voltage limits at mains terminals	10
3.1.2 Disturbance voltage limits at load and control terminals	10
3.2 Block Diagram of Test Setup	11
3.3 Test Setup and Test Procedure	12
3.3.1 Test setup	12
3.3.2 Test procedure.....	13
3.4 Test Protocol	14
3.5 Emission waveform.....	15
3.6 Measurement Uncertainty	16
3.7 Additions, Deviations and Exclusions from Standards	16
4. Radiated Electromagnetic Disturbance.....	17
4.1 Radiated Electromagnetic Disturbance Limit for frequency range 9kHz to 30MHz.....	17
4.2 Block Diagram of Test Setup	18
4.3 Test Setup and Test Procedure	18
4.4 Test Protocol	19
4.5 Emission waveform.....	20
4.5 Measurement Uncertainty	20
4.6 Additions, Deviations and Exclusions from Standards	20
5. Insertion Loss.....	21
5.1 Insertion loss limit	21
5.2 Block diagram of test set up	22
5.3 Test Procedure	25
5.4 Test Protocol	25
5.5 Test Facility Description	25
5.6 Measurement Uncertainty	25
5.7 Additions, Deviations and Exclusions from Standards	25
6. Radiated emission	26
6.1 Radiated emission limit from frequency range 30MHz – 300MHz.....	26
6.2 Block diagram and test set up.....	26
6.3 Test Protocol	27
6.4 Measurement uncertainty	27
6.5 Additions, Deviations and Exclusions from Standards	27
7. Harmonics	28

7.1 Block Diagram of Test Setup	28
7.2 Test Setup and Test Procedure	28
7.3 Test Protocol	29
7.4 Measurement Uncertainty	31
8. Voltage Fluctuations-Flicker	32
8.1 Block Diagram of Test Setup	32
8.2 Test Setup and Test Procedure	32
8.2.1 Definition.....	32
8.2.2 Test condition	32
8.3 Test Protocol	33
The EUT has no means to generate the flicker exceed the specific limit, So it is deemed to fulfill with the requirement without testing.....	33
8.4 Measurement Uncertainty	33
Immunity Test.....	34
9. Electrostatic Discharge (ESD)	35
9.1 Severity Level and Performance Criterion	35
9.1.1 Test level.....	35
9.1.2 Performance Criterion.....	35
9.2 Block Diagram of Test Setup	36
9.3 Test Setup and Test Procedure	37
9.4 Test Protocol	38
9.5 Measurement Uncertainty	39
9.6 Additions, Deviations and Exclusions from Standards	39
10. Electromagnetic field susceptibility	40
10.1 Severity Level and Performance Criterion	40
10.1.1 Test level.....	40
10.1.2 Performance Criterion.....	40
10.2 Block diagram of test setup	41
10.3 Test Setup and Test Procedure	41
10.4 Test Protocol.....	42
10.5 Measurement Uncertainty	42
10.6 Additions, deviations and exclusions from standards.....	42
11. Electric Fast Transient/Burst Immunity Test.....	43
11.1 Severity Level and Performance Criterion	43
11.1.1 Test level.....	43
11.1.2 Performance Criterion.....	43
11.2 Block Diagram of Test Setup	44
11.2.1 Block Diagram for input a.c./d.c. power line	44
11.3 Test Setup and Test Procedure	46
11.5 Measurement Uncertainty	46
11.6 Additions, Deviations and Exclusions from Standards	46
12. Surge Immunity Test.....	47
12.1 Severity Level and Performance Criterion	47
12.1.1 Test level.....	47
12.1.2 Performance Criterion.....	47
12.2 Block Diagram of Test Setup	48
12.3 Test Setup and Test Procedure	48
12.4 Test Protocol.....	49
12.5 Measurement Uncertainty	49
12.6 Additions, Deviations and Exclusions from Standards	49

13. Immunity to Conducted Disturbances, Induced by Radio-frequency Fields	50
13.1 Severity Level and Performance Criterion	50
13.1.1 Test level.....	50
13.1.2 Performance Criterion.....	50
13.2 Block Diagram of Test Setup	51
Block Diagram for a.c./d.c input power line	51
13.3 Test Setup and Test Procedure	53
13.4 Test Protocol.....	53
13.5 Measurement Uncertainty	53
13.6 Additions, Deviations and Exclusions from Standards	53
14. Voltage Dips, Short Interruptions and Voltage Variations Immunity Test.....	54
14.1 Severity Level and Performance Criterion	54
14.1.1 Test level.....	54
14.1.2 Performance Criterion.....	54
14.2 Block diagram of test setup	55
14.3 Test Setup and Test Procedure	55
14.4 Test Protocol.....	56
14.5 Measurement Uncertainty	56
14.6 Additions, deviations and exclusions from standards.....	56
Appendix I: Photograph of Test setup.....	57
Appendix II: Photograph of EUT	58

1.GENERAL INFORMATION

1.1 Description of Equipment Under Test (EUT)

EUT	:	EMC Condensor
Description of EUT	:	There is only one model. All tests were performed on the model and the worst test data is listed in the report.
Model number	:	KY48C
Rating	:	230V~, 50Hz
Mains lead	:	0.0 m, (un)shielded, (non)detachable
Data cable	:	none
Sample received date	:	2009-05-25
Date of test	:	2009-05-25~06-09
EUT type	:	<input checked="" type="checkbox"/> Table top <input type="checkbox"/> Floor standing

1.2 Description of Client

Applicant	:	Taizhou Jiaojiang Huatai Industry & Trade Co.,Ltd. No.1 Zhengqian Road, Xiacheng Town, Jiaojiang ,Taizhou 318010 P. R. China
Person of contact	:	Mr. ShengWenBin
Telephone	:	86 576 85688353
Telefax	:	86 576 85688231
Manufacturer	:	Taizhou Jiaojiang Huatai Industry & Trade Co.,Ltd. No.1 Zhengqian Road, Xiacheng Town, Jiaojiang ,Taizhou 318010 P. R. China

1.3 Description of Test Facility

Name Intertek Testing Services Hangzhou Limited.
Address 16 No. 1 Ave., Xiasha Economic Development
District, Hangzhou 310018, China
Telephone 86 571 28997803
Telefax 86 571 28997888

Subcontractor :

- Name Intertek Testing Service Shanghai Limited
Address Building 86, No. 1198 Qinzhou Road(North),
Shanghai 200233, P.R. China
Telephone 86 21 61278200
- Name Shanghai Institute of Measurement Technology
Address 716 Yishan Road, Shanghai 200233, P.R. China
Telephone 86 21 64701390

2. TEST SPECIFICATIONS

2.1 Standards

EN55015: 2006: Limits and methods of measurement of radio disturbance characteristics of electrical lighting and similar equipment

EN61547: 1995/+A1: 2000: Equipment for general lighting purposed EMC immunity requirements

EN61000-3-2: 2006: Limits for harmonic current emissions (equipment input current $\leq 16\text{A}$ per phase)

EN61000-3-3:1995/+A1:2001/+A2:2005: Limitation of voltage fluctuations and flicker in low-voltage supply systems for equipment with rated current $\leq 16\text{A}$

2.2 Mode of operation during the test

Within this test report, EUT was tested under all available operation mode (lighting) and tested under its rating voltage and frequency (230V~, 50Hz). Other voltage and frequency is specified if used.

2.3 Instrument list

	Instrument	Code	Model	Due date
<input checked="" type="checkbox"/>	EMI test receiver	EH 2003	ESCI	2009-6-14
<input checked="" type="checkbox"/>	A.M.N.	EH 2005	ESH2-Z5	2009-6-15
<input type="checkbox"/>	Passive Voltage probe	EH 2004	ESH2-Z3	2009-6-14
<input type="checkbox"/>	Absorbing clamp	EH 1331	MDS 21	2009-6-14
<input type="checkbox"/>	2m loop antenna	EH 1332	HXYZ9170	2009-6-14
<input checked="" type="checkbox"/>	Harmonic-flicker sys.	EH 2008	DPA 500	2009-6-13
<input checked="" type="checkbox"/>	AC Power Supply	EH 2008-1	ACS 500	2009-6-13
<input type="checkbox"/>	Conduct immunity sys.	EH 2013	UCS 500M6B	2009-8-17
<input type="checkbox"/>	Automatic transformer	EH 2014	MV2616	Not required
<input type="checkbox"/>	Capacity clamp	EH 2017	HFK	Not required
<input type="checkbox"/>	ESD generator	EH 1330	KES4021	2009-7-09
<input type="checkbox"/>	Magnetic loop	EH 2016	MS 100	2009-6-14
<input type="checkbox"/>	Current transformer	EH 2015	MC 2630	2009-6-14
<input type="checkbox"/>	Injected current	EH 2009	CWS 500	2009-6-14
<input type="checkbox"/>	Attenuator	EH 2010	ATT6/75	2009-6-15
<input type="checkbox"/>	CDN	EH 2011	M2/M3	2009-6-15
<input type="checkbox"/>	EM clamp	EH 2012	EM 101	2009-6-14
<input type="checkbox"/>	Oscilloscope	EH 1236	TDS3012B	2009-7-28
<input checked="" type="checkbox"/>	Digital lux meter	EH 2085	ZDS-10	2009-12-20
<input type="checkbox"/>	Lamp holder	EH 1329	-	Not required
<input checked="" type="checkbox"/>	Therom-Hygrograph	EH 1099	ZJ1-2A	2009-6-27
<input checked="" type="checkbox"/>	Therom-Hygrograph	EH 1098	ZJ1-2A	2009-6-27
<input type="checkbox"/>	Therom-Hygrograph	EH 1091	ZJ1-2A	2009-6-27
<input type="checkbox"/>	Tonometer	EH 1423	YM3	2009-10-29
<input type="checkbox"/>	Isolation transformer	EH 1171	-	Not required
<input type="checkbox"/>	Multi-meter	EH 1016	F179	2009-11-16
<input type="checkbox"/>	Shielded room 2	EH 1183	GB88	2011-1-4
<input checked="" type="checkbox"/>	Shielded room 1	EH 1184	GB88	2011-1-4

2.4. Test Summary

This report applies to tested sample only. This report shall not be reproduced in part without written approval of Intertek Testing Service Hangzhou Limited.

TEST ITEM	PASSED THE TEST	NOTE
Mains terminal continuous disturbance voltage	Pass	
Radio frequency magnetic field emission	NA	
Radiated emission	NA	*
Harmonics	Pass	
Voltage fluctuation-Flicker	Pass	
Insertion loss	NA	
Electrostatic Discharge (ESD)	NA	
Electric Fast Transient /Burst (EFT/B)	NA	
Surge	NA	
Injected Current	NA	
RF electromagnetic field susceptibility	NA	*
Voltage dips and interruption	NA	

Notes: 1: NA =Not Applicable

2: Margin to the limit is within the uncertainty interval of the measured value.

3. "*" means this test is subcontracted if have

4: Incandescent lamp luminaires where the lamps are a.c. mains or d.c. operated, or which do not incorporate a light regulating device or electronic switch, are not expected to produce electromagnetic disturbances. Therefore, they are deemed to fulfil all relevant requirements of this standard without further testing.

Emission Test

3. Mains/Load/Control Terminal Continuous Disturbance Voltage

Test result: PASS

3.1 Terminal Voltage Limits for the frequency range 9kHz to 30MHz

3.1.1 Disturbance voltage limits at mains terminals

Frequency range (MHz)	Limits dB(μV)	
	Quasi-peak	Average
0.009 ~ 0.05	110	-
0.05 ~ 0.15	90 ~ 80 *	-
0.15 ~ 0.5	66 ~ 56 *	56 ~ 46 *
0.5 ~ 5	56	46
5 ~ 30	60	50

Note : 1. * means the limit decreasing linearly with the logarithm of the frequency in the range 0.05MHz ~ 0.15MHz and 0.15MHz to 0.5MHz
2. If the limit for the measurement with the average detector is met when using a receiver with a quasi-peak detector, the equipment under test shall be deemed to meet both limits and the measurement using the receiver with an average detector need not be carried out.

3.1.2 Disturbance voltage limits at load and control terminals

Frequency range (MHz)	Limits dB(μV)	
	Quasi-peak	Average
0.15 ~ 0.5	80	70
0.5 ~ 5	74	64
5 ~ 30	74	64

Note: 1. If the limit for the measurement with the average detector is met when using a receiver with a quasi-peak detector, the equipment under test shall be deemed to meet both limits and the measurement using the receiver with an average detector need not be carried out.

3.2 Block Diagram of Test Setup

At mains terminal

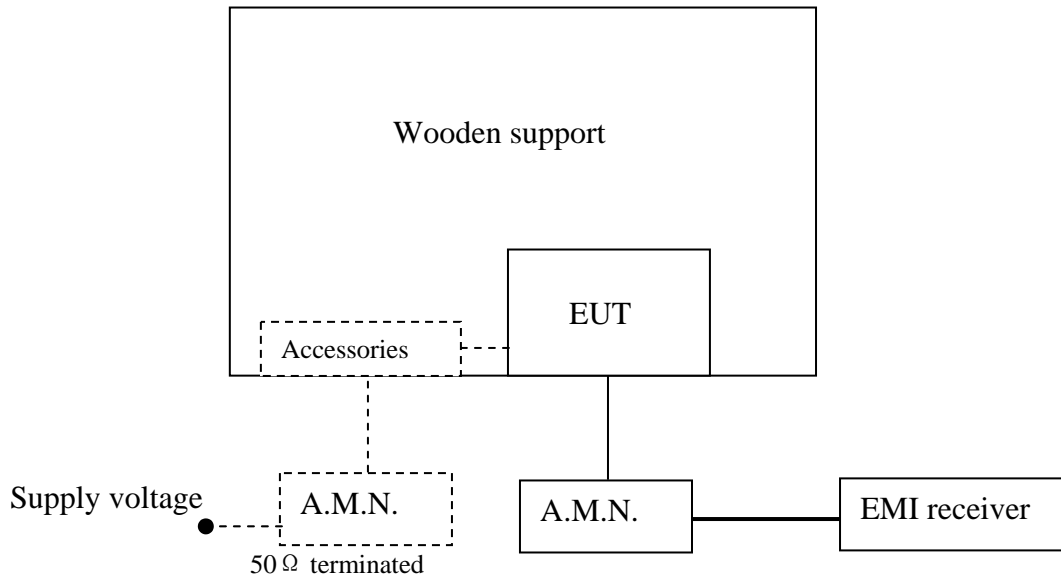

For table top equipment, wooden support is 0.8m height table

For floor standing equipment, wooden support is 0.1m height rack.

At output and control terminals

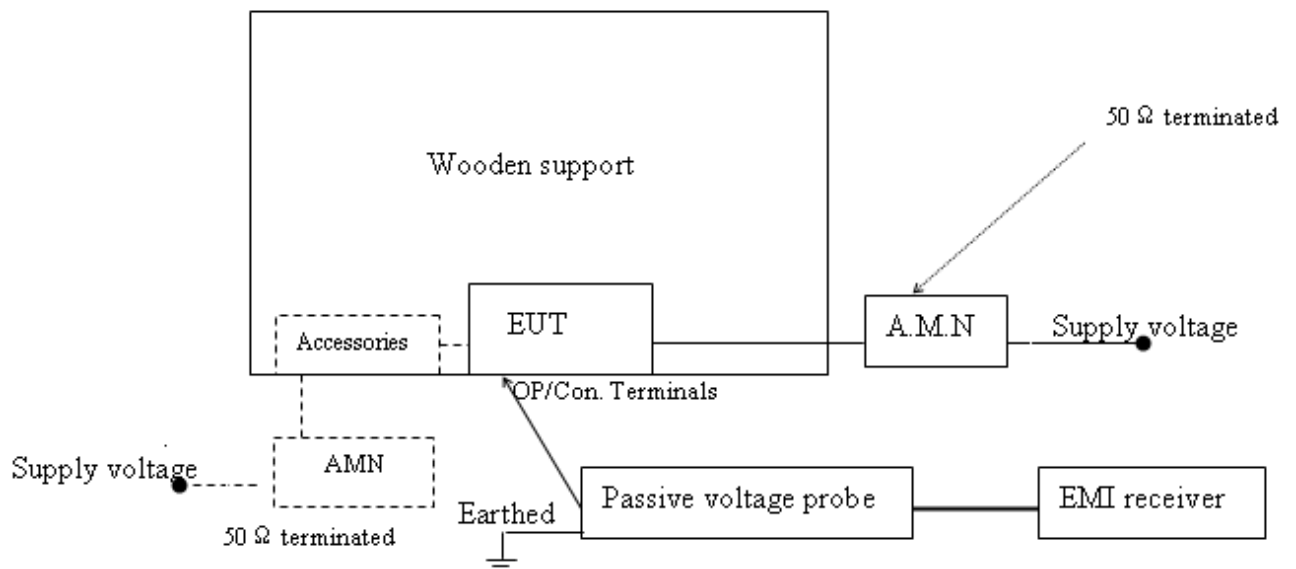

Note:
 ————— : power line
 ————— : signal line
 - - - - - : means the test setup while available

3.3 Test Setup and Test Procedure

3.3.1 Test setup

Detailed test procedure and arrangement was follow EN 55015 clause 8.1.
Operation conditions of EUT was according to EN 55015 clause 6
Measurement was carried out with lamps which have been in operation for:

- 2h for incandescent lamps;
- 100h for fluorescent lamps

Prior to a measurement, the lamps were operated until stabilization has been reached, and the following stabilization time was observed:

- 5 min for incandescent lamp;
- 15 min for fluorescent lamp;
- 30 min for other discharge lamps

3.3.2 Test procedure

All measurements were according to EN55015 clause 10.1, 10.2, 10.3 and For:

- Self-contained emergency lighting luminaires

The measurement was carried in accordance with EN55015 clause 8.8

- UV and IR radiation appliances

The measurement was carried in accordance with EN55015 clause 8.7

- Independent auxiliaries exclusively for use with lighting equipment.

The measurement was carried in accordance with EN55015 clause 8.3 & 8.5 & 8.9

- Self-ballasted lamps

The measurement was carried in accordance with EN55015 clause 8.6

- Independent transformers and convertors for incandescent lamps

The measurement was carried in accordance with EN55015 clause 8.4

- Indoor luminaires

The measurement was carried in accordance with EN55015 clause 8.2

- Out door lighting appliances

The measurement was carried in accordance with EN55015 clause 8.2

The frequency from 9kHz to 30MHz was checked.

The bandwidth of test receiver was set on 200Hz (from 9kHz to 150kHz) and 9kHz (from 150kHz to 30MHz).

3.4 Test Protocol

Temperature : 22 °C
Relative Humidity : 53 %

For mains terminal

Frequency (MHz)	Quasi-peak		Average	
	Disturbance level dB(uV)	Permitted limit dB(uV)	Disturbance level dB(uV)	Permitted limit dB(uV)
0.009	*	110.00	-	-
0.05	*	90.00	-	-
0.10	*	83.69	-	-
0.16	*	65.46	*	55.46
0.24	*	62.10	*	52.10
0.55	*	56.00	*	46.00
1.00	*	56.00	*	46.00
1.40	*	56.00	*	46.00
2.00	*	56.00	*	46.00
3.50	*	56.00	*	46.00
6.00	*	60.00	*	50.00
10.00	*	60.00	*	50.00
22.00	*	60.00	*	50.00
30.00	*	60.00	*	50.00

Note: * means the emission level 20dB lower than the relevant limit.

For load/control terminal : NA

Frequency (MHz)	Quasi-peak		Average	
	Disturbance level dB(μV)	Permitted limit dB(μV)	Disturbance level dB(μV)	Permitted limit dB(μV)
-	-	-	-	-
-	-	-	-	-
-	-	-	-	-

Note: * means the emission level 20dB below the relevant limit.

3.5 Emission waveform

L line

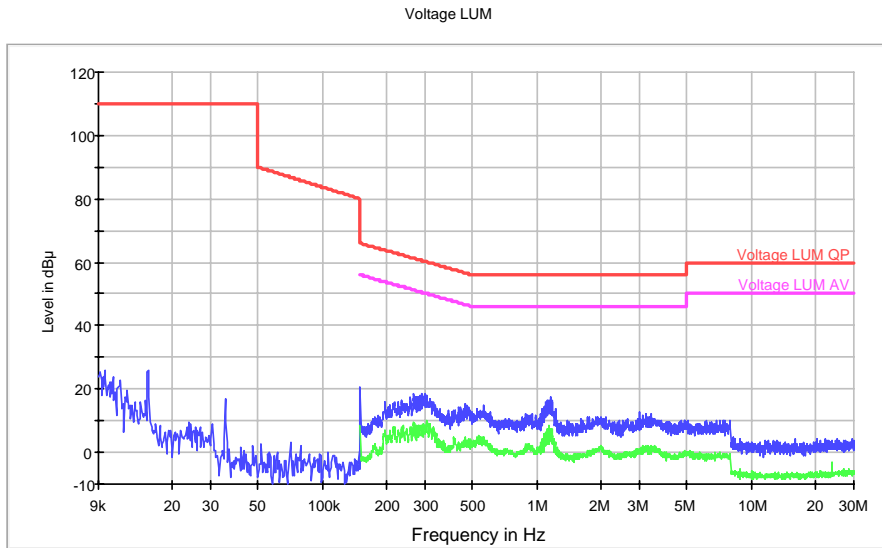

N line

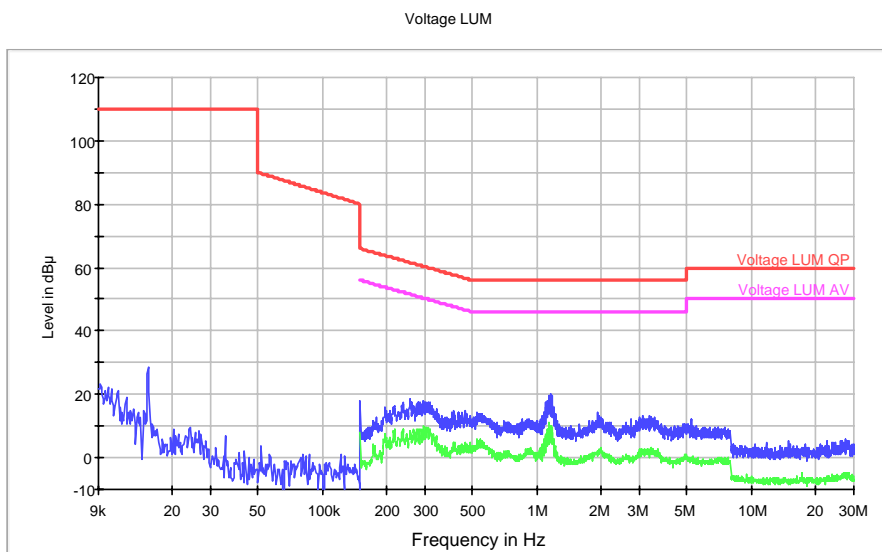

3.6 Measurement Uncertainty

The measurement uncertainty describes the overall uncertainty of the given measured value during the operation of the EUT.

Measurement uncertainty at mains terminal: $\pm 1.95\text{dB}$ (0.15-30MHz), $\pm 2.02\text{dB}$ (9-150kHz)

Measurement uncertainty at load/control terminal: $\pm 1.57\text{dB}$

The measurement uncertainty is given with a confidence of 95%, $k=2$.

The measurement uncertainty is traceable to internal procedure TI-036.

3.7 Additions, Deviations and Exclusions from Standards

None.

4. Radiated Electromagnetic Disturbance

Test result: NA

4.1 Radiated Electromagnetic Disturbance Limit for frequency range 9kHz to 30MHz

Frequency Range	Limits for loop diameter dB(μ A) (a)		
	2m	3m	4m
9kHz – 70kHz	88	81	75
70kHz - 150kHz	88 to 58 (b)	81 to 51 (b)	75 to 45(b)
150kHz - 2.2MHz	58 to 26 (b)	51 to 22 (b)	45 to 16 (b)
2.2MHz – 3.0MHz	58	51	45
3.0MHz – 30MHz	22	15 to 16 (c)	9 to 12 (c)

Notes:

- a: At the transition frequency, the lower limit applies.
- b: Decreasing linearly with the logarithm of the frequency.
- c: Increasing linearly with the logarithm of the frequency.

4.2 Block Diagram of Test Setup

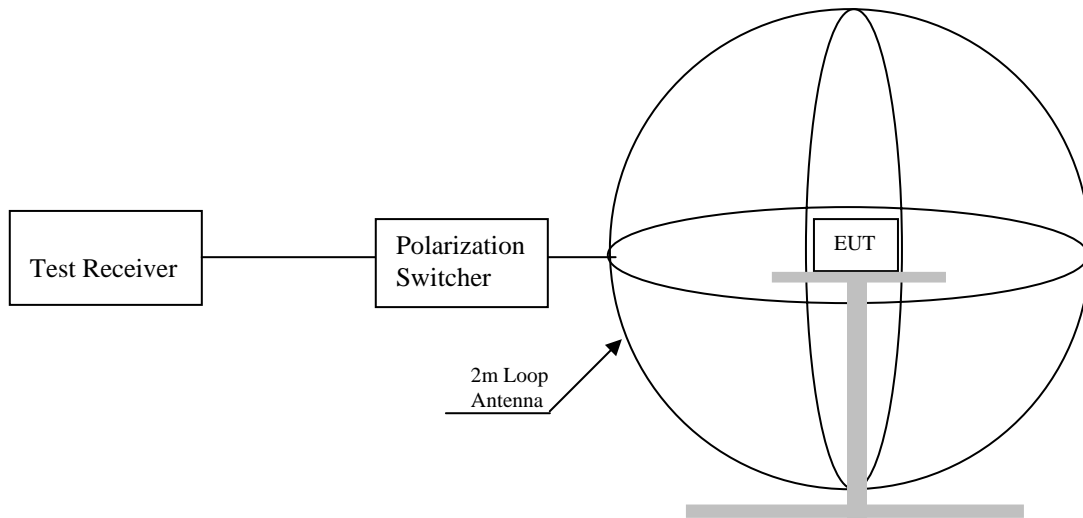

4.3 Test Setup and Test Procedure

Measurement was performed in shielded room, and instruments used were follow EN 55015 clause 9.1.1.

Detailed test procedure and arrangement was follow EN 55015 clause 9.1.

Frequency range 9kHz – 30MHz was checked and EMI receiver measurement bandwidth was set to 200Hz (from 9kHz to 150kHz) and 9kHz (from 150kHz to 30MHz).

4.4 Test Protocol

Temperature : °C
Relative Humidity : %

Frequency /MHz	Quasi-peak (dBμA) Disturbance level			Permitted limit
	X direction	Y direction	Z direction	
0.009				88.00
0.05				88.00
0.10				73.96
0.16				65.46
0.24				52.40
0.55				42.52
1.00				35.39
1.40				31.39
2.00				27.14
3.50				22.00
6.00				22.00
10.00				22.00
22.00				22.00
30.00				22.00

Notes: * means the disturbance power level 20dB lower than the relevant limit.

4.5 Emission waveform

X direction:

Y direction:

Z direction:

4.5 Measurement Uncertainty

The measurement uncertainty describes the overall uncertainty of the given measured value during the operation of the EUT.

Measurement uncertainty at mains terminal: $\pm 2.53\text{dB}$

The measurement uncertainty is given with a confidence of 95%, $k=2$.

The measurement uncertainty is traceable to internal procedure TI-036.

4.6 Additions, Deviations and Exclusions from Standards

None

5. Insertion Loss

Test result: NA

5.1 Insertion loss limit

Frequency range (kHz)	Minimum Values (dB)
150 to 160	28
160 to 1400	28 to 20*
1400 to 1605	20

* Decreasing linearly with the logarithm of frequency

5.2 Block diagram of test set up

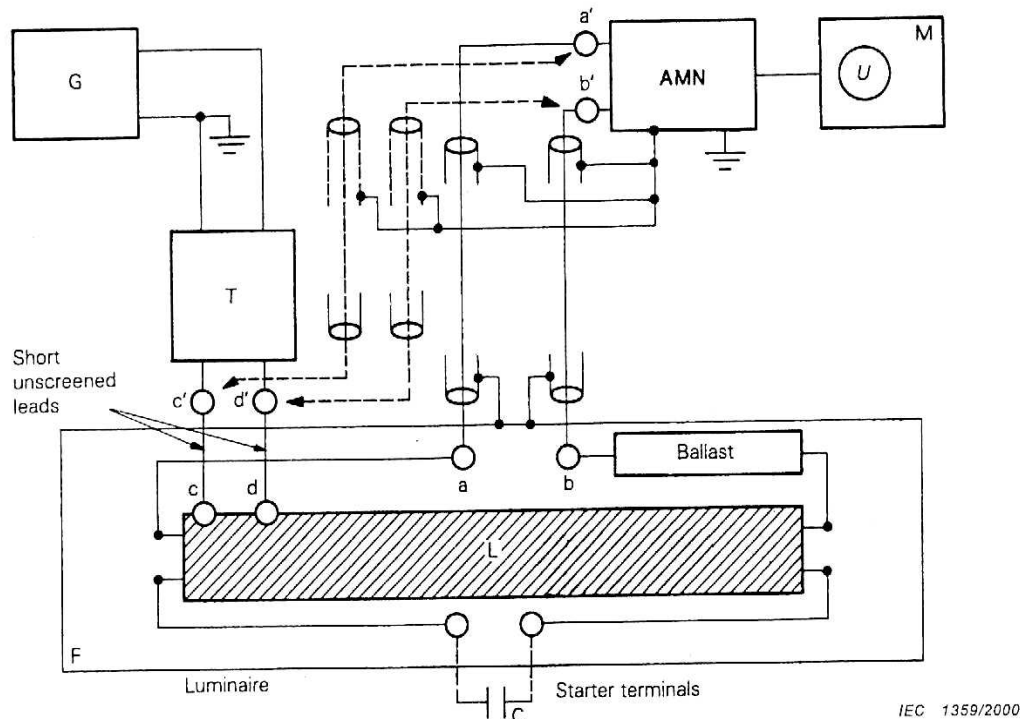

Key

- G = r.f. generator
- T = balance-to-unbalance transformer
- AMN = 50 Ω/50 μH + 5 Ω (or 50 Ω/50 μH) artificial mains network as specified in CISPR 16-1
- M = r.f. millivoltmeter or measuring receiver
- L = dummy lamp
- F = luminaire
- C = capacitor
- a – b = mains terminals
- a' – b' = input terminals of the measuring network AMN
- c – d = r.f. terminals of dummy lamp L
- c' – d' = output terminals of T
- a – a' and b – b' = connections by coaxial cables ($Z_0 = 75 \Omega$), with the respective ends of the screens connected to the reference earth of AMN and F not exceeding 50 cm in length
- c – c' and d – d' = connections of the transformer to the dummy lamp shall be made with unscreened leads not exceeding 100 mm in length

NOTE When measuring U-type lamp luminaires, the same circuit arrangement is used, but the linear dummy lamp should be replaced by the U-type dummy lamp.

Figure 1 – Insertion loss measurement on linear and U-type fluorescent lamp luminaires

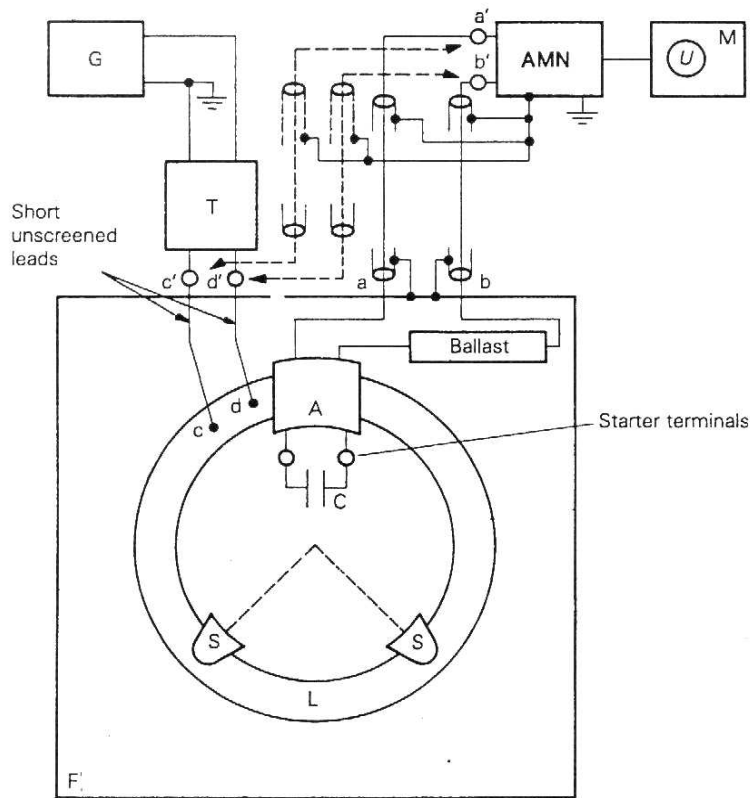

IEC 1360/2000

Key

- G = r.f. generator
- T = balance-to-unbalance transformer
- AMN = 50 Ω/50 μH + 5 Ω (or 50 Ω/50 μH) artificial mains network as specified in CISPR 16-1
- M = r.f. millivoltmeter or measuring receiver
- L = dummy lamp
- F = luminaire
- C = capacitor
- A = lampholder
- S = supports of insulating material
- a – b = mains terminals
- a' – b' = input terminals of the measuring network AMN
- c – d = r.f. terminals of dummy lamp L
- c' – d' = output terminals of T
- a – a' and b – b' = connections by coaxial cables ($Z_0 = 75 \Omega$), with the respective ends of the screens connected to the reference earth of AMN and F, not exceeding 50 cm in length
- c – c' and d – d' = connections of the transformer to the dummy lamp shall be made with unscreened leads not exceeding 100 mm in length

Figure 2 – Insertion loss measurement on circular fluorescent lamp luminaires

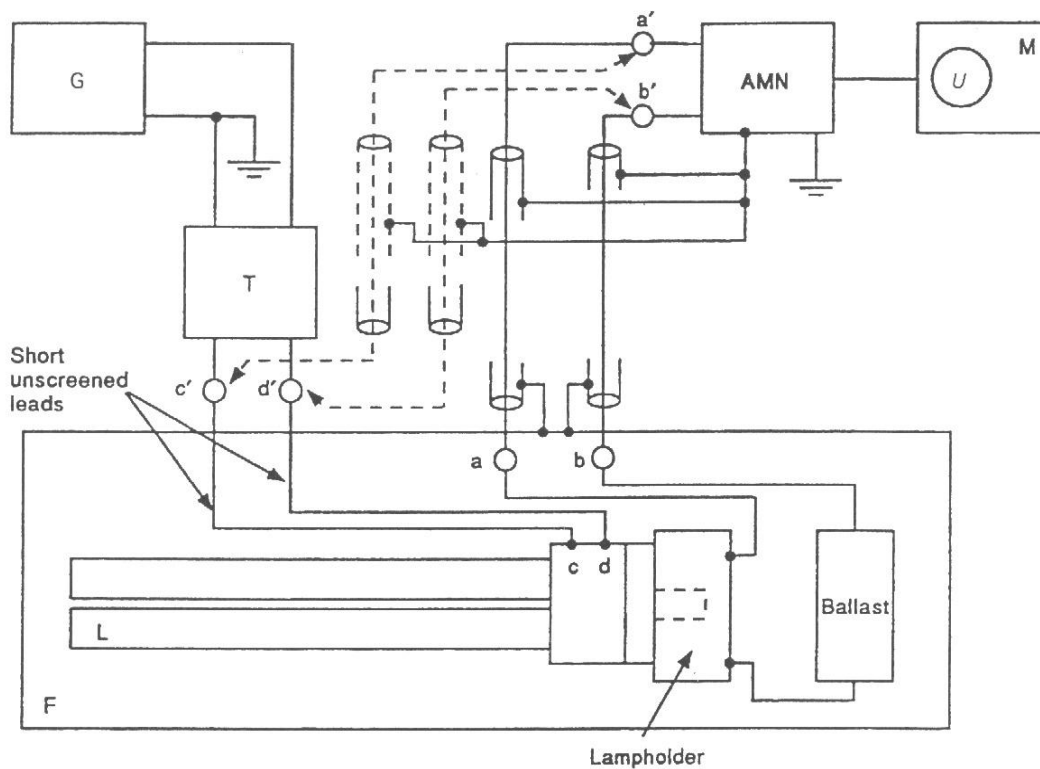

IEC 1361/2000

Key

- G = r.f. generator
- T = balance-to-unbalance transformer
- AMN = 50 Ω/50 μH + 5 Ω (or 50 Ω/50 μH) artificial mains network as specified in CISPR 16-1
- M = r.f. millivoltmeter or measuring receiver
- L = dummy lamp
- F = luminaire
- a – b = mains terminals
- a' – b' = input terminals of the measuring network AMN
- c – d = r.f. terminals of dummy lamp L
- c' – d' = output terminals of T
- a – a' and b – b' = connections by coaxial cables ($Z_0 = 75 \Omega$), with the respective ends of the screens connected to the reference earth of AMN and F, not exceeding 50 cm in length
- c – c' and d – d' = connections of the transformer to the dummy lamp shall be made with unscreened leads not exceeding 100 mm in length

Figure 3 – Insertion loss measurement on luminaires for single-capped fluorescent lamps with integrated starter

5.3 Test Procedure

Detailed test procedure and arrangement was follow EN 55015 clause 7.2 and clause 7.4

5.4 Test Protocol

Temperature : °C
Relative Humidity : %

5.5 Test Facility Description

The test and test instruments mentioned above was conducted in the following test facility:

**Shanghai Institute of Measurement and Testing Technology EMC lab.
716 Yishan Road, Shanghai, China 200233**

Which is a general test laboratory.

5.6 Measurement Uncertainty

According to CISPR 16-4-2: 2003, measurement uncertainty is under consideration.

5.7 Additions, Deviations and Exclusions from Standards

None

6. Radiated emission

Test result: NA

6.1 Radiated emission limit from frequency range 30MHz – 300MHz

Frequency (MHz)	Permitted limit in dB μ V/m (Quasi-peak) of Measurement Distance 3m	Permitted limit in dB μ V/m (Quasi-peak) of Measurement Distance 10m
30-230	40	30
230-300	47	37

Note: 1. For the measurement distance other than 3m and 10m, the limit is varied according to 20dB/10 decades.
2. The gray rows are selected items.

6.2 Block diagram and test set up

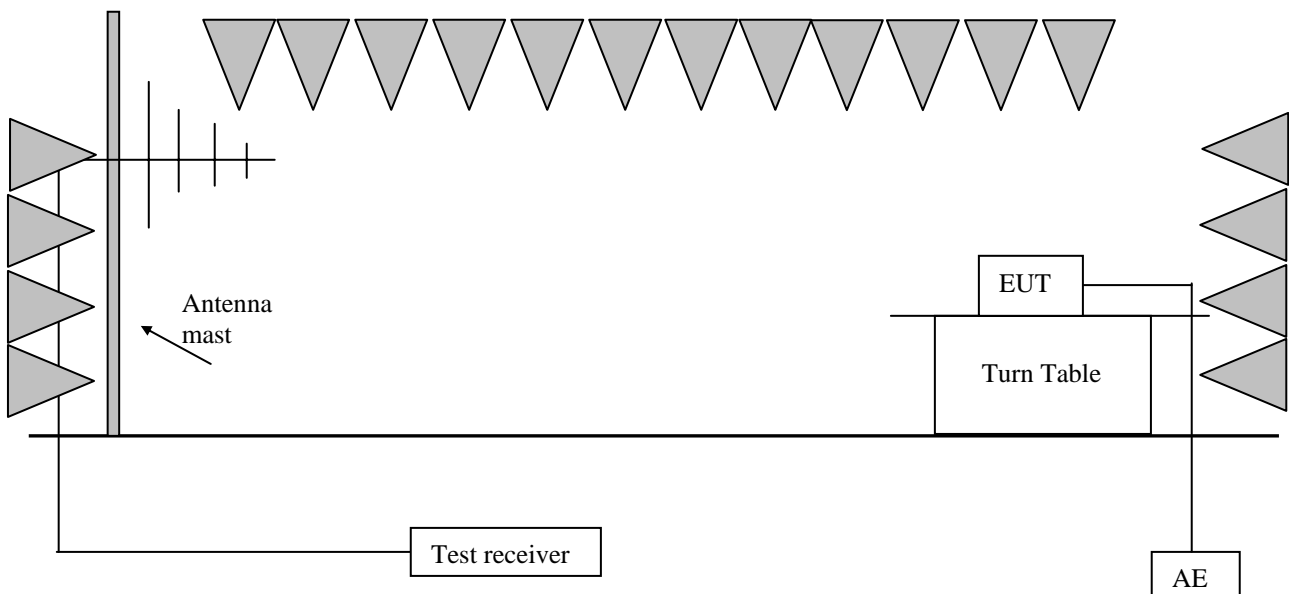

The measurement was applied in a semi-anechoic chamber.
Measurement was performed according to CISPR 22.
Setting of EUT is according to EN 55015 Annex C.
The bandwidth setting on R&S Test Receiver ESI26 was 120kHz.
The frequency range from 30MHz to 300MHz was checked.

6.3 Test Protocol

Temperature: °C Relative humidity: %

Horizontal

Vertical

6.4 Measurement uncertainty

The measurement uncertainty describes the overall uncertainty of the given measured value during the operation of the EUT.

Measurement uncertainty of radiated emission is: $\pm 5.31\text{dB}$

The measurement uncertainty is given with a confidence of 95%, $k=2$.

The measurement uncertainty is traceable to internal procedure TI-036.

6.5 Additions, Deviations and Exclusions from Standards

None.

7. Harmonics

Test result: PASS

7.1 Block Diagram of Test Setup

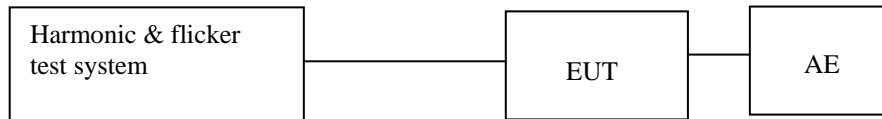

7.2 Test Setup and Test Procedure

Harmonics of the fundamental current were measured up to 40 order harmonics using a digital power meter with an analogue output and frequency analyser which was integrated in the harmonic & flicker test system. The measurements were carried out under steady conditions .

Measuring instrumentation according to IEC 61000-4-7:2002

7.3 Test Protocol

Temperature : 22 °C Relative Humidity : 53 %

Power and THD results

True power P:	40.88W	Apparent power S:	40.97VA
Reactiv power Q:	2.59var	Power factor:	0.998
THD (U):	0.001	THD (I):	0.023
Crest Factor (U):	1.414	Crest Factor (I):	1.409

Average harmonic current results

Hn	I _{eff} [A]	I _{eff} [%]	Limit [%]	Result
1	177.915E-3	99.652		
2	661.467E-6	0.370	2.00	PASS
3	2.981E-3	1.670	29.94	PASS
4	1.747E-3	0.979		PASS
5	1.886E-3	1.056	10.00	PASS
6	688.947E-6	0.386		PASS
7	607.399E-6	0.340	7.00	PASS
8	661.921E-6	0.371		PASS
9	963.974E-6	0.540	5.00	PASS
10	637.804E-6	0.357		PASS
11	634.466E-6	0.355	3.00	PASS
12	690.953E-6	0.387		PASS
13	730.053E-6	0.409	3.00	PASS
14	899.906E-6	0.504		PASS
15	638.181E-6	0.357	3.00	PASS
16	666.592E-6	0.373		PASS
17	618.031E-6	0.346	3.00	PASS
18	980.779E-6	0.549		PASS
19	646.503E-6	0.362	3.00	PASS
20	639.307E-6	0.358		PASS
21	688.900E-6	0.386	4.50	PASS
22	728.159E-6	0.408		PASS
23	939.943E-6	0.526	4.50	PASS
24	597.347E-6	0.335		PASS
25	602.054E-6	0.337	4.50	PASS
26	568.746E-6	0.319		PASS
27	866.473E-6	0.485	4.50	PASS
28	578.745E-6	0.324		PASS
29	587.392E-6	0.329	4.50	PASS
30	653.141E-6	0.366		PASS
31	782.134E-6	0.438	4.50	PASS
32	848.402E-6	0.475		PASS
33	724.385E-6	0.406	4.50	PASS
34	700.534E-6	0.392		PASS
35	598.188E-6	0.335	4.50	PASS
36	968.542E-6	0.542		PASS
37	810.793E-6	0.454	4.50	PASS
38	812.518E-6	0.455		PASS
39	773.559E-6	0.433	4.50	PASS
40	716.081E-6	0.401		PASS

Maximum harmonic current results

Hn	I _{eff} [A]	I _{eff} [%]	Limit [%]	Result
1	178.536E-3	100.000		
2	762.969E-6	0.427	3.00	PASS
3	3.085E-3	1.728	44.92	PASS
4	1.921E-3	1.076		PASS
5	2.150E-3	1.204	15.00	PASS
6	789.251E-6	0.442		PASS
7	670.162E-6	0.375	10.50	PASS
8	761.685E-6	0.427		PASS
9	1.050E-3	0.588	7.50	PASS
10	730.138E-6	0.409		PASS
11	711.683E-6	0.399	4.50	PASS
12	830.912E-6	0.465		PASS
13	913.924E-6	0.512	4.50	PASS
14	1.025E-3	0.574		PASS
15	735.804E-6	0.412	4.50	PASS
16	736.463E-6	0.413		PASS
17	706.623E-6	0.396	4.50	PASS
18	1.223E-3	0.685		PASS
19	726.990E-6	0.407	4.50	PASS
20	738.917E-6	0.414		PASS
21	757.774E-6	0.424	4.50	PASS
22	945.508E-6	0.530		PASS
23	1.066E-3	0.597	4.50	PASS
24	673.328E-6	0.377		PASS
25	695.340E-6	0.389	4.50	PASS
26	629.850E-6	0.353		PASS
27	1.000E-3	0.560	4.50	PASS
28	656.952E-6	0.368		PASS
29	707.475E-6	0.396	4.50	PASS
30	733.084E-6	0.411		PASS
31	962.101E-6	0.539	4.50	PASS
32	970.314E-6	0.543		PASS
33	797.788E-6	0.447	4.50	PASS
34	821.833E-6	0.460		PASS
35	717.158E-6	0.402	4.50	PASS
36	1.168E-3	0.654		PASS
37	899.242E-6	0.504	4.50	PASS
38	885.723E-6	0.496		PASS
39	856.719E-6	0.480	4.50	PASS
40	898.045E-6	0.503		PASS

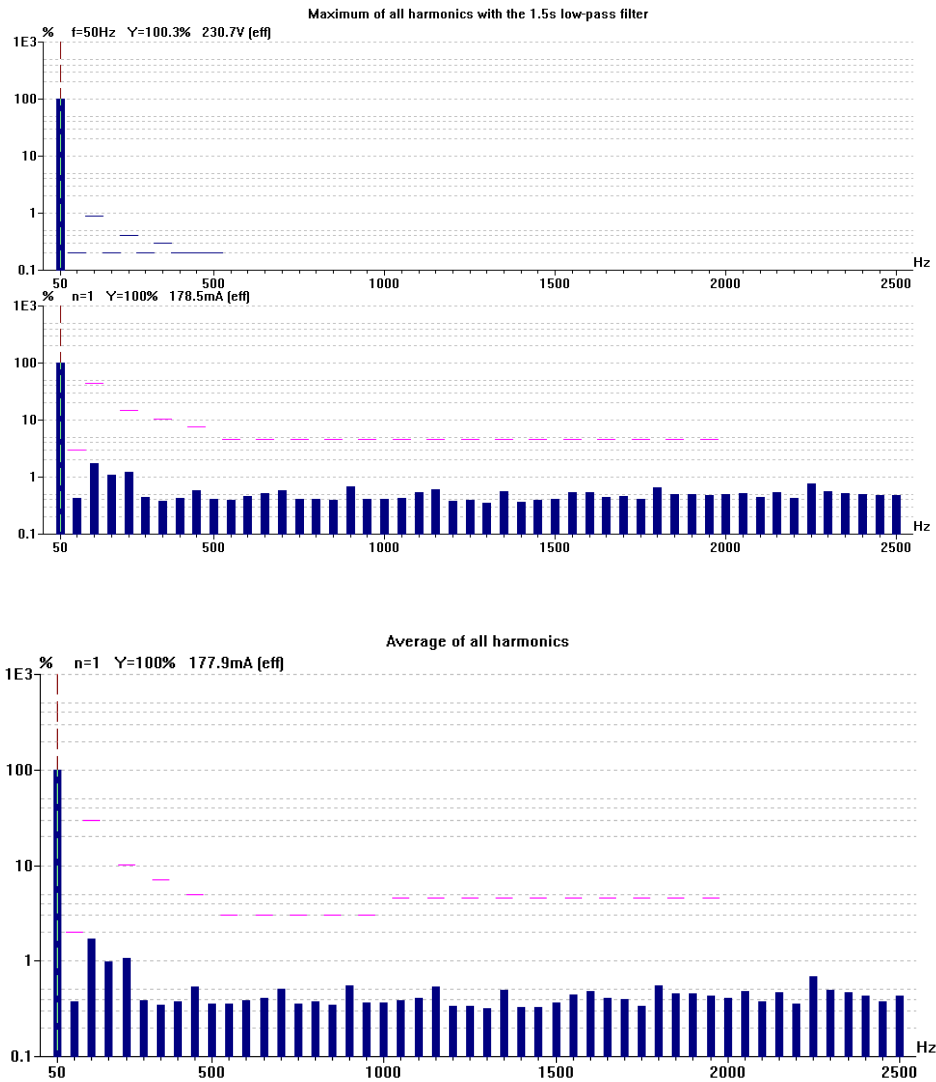

7.4 Measurement Uncertainty

The measurement uncertainty describes the overall uncertainty of the given measured value during the operation of the EUT.

Measurement uncertainty of harmonic test is: $\pm 3.15\%$

The measurement uncertainty is given with a confidence of 95%, $k=2$.

The measurement uncertainty is traceable to internal procedure TI-036.

8. Voltage Fluctuations-Flicker

Test result **PASS**

8.1 Block Diagram of Test Setup

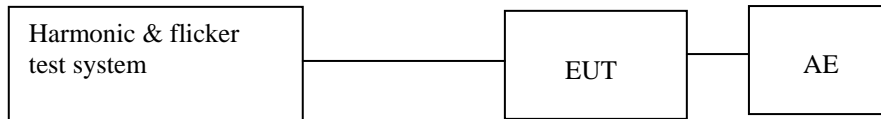

8.2 Test Setup and Test Procedure

8.2.1 Definition

- Flicker:** impression of unsteadiness of visual sensation induced by a lighting stimulus whose luminance or spectral distribution fluctuates with time.
- Pst:** Short-term flicker indicator The flicker severity evaluated over a short period (in minutes); Pst=1 is the conventional threshold of irritability
- Plt:** long-term flicker indicator; the flicker severity evaluated over a long period (a few hours). Using successive Pst values.
- dc:** the relative steady-state voltage change
- dmax:** the maximum relative voltage change
- d(t):** the value during a voltage change

8.2.2 Test condition

The EUT was set to produce the most unfavorable sequence of voltage changes.

8.3 Test Protocol

The tested object operated under the operating condition specified in EN61000-3-3
The following limits apply

- "Pst" shall not exceed 1.0.
- "dc" shall not exceed 3.3%.
- d(t) shall not exceed 3.3% for more than 500ms.
- "dmax" shall not exceed:

- 4% without additional conditions,
- 6% switched manually or automatically more than twice per day
- 7% attended whilst in use or switched automatically for no more than twice per day or attended while in use
- for manual switch, dmax is measured in accordance with Annex B of standard, average dmax is calculated from 24 times measurement

Temperature: °C Relative Humidity: %

- The EUT has no means to generate the flicker exceed the specific limit, So it is deemed to fulfill with the requirement without testing.

8.4 Measurement Uncertainty

The measurement uncertainty describes the overall uncertainty of the given measured value during the operation of the EUT.

Measurement uncertainty of voltage fluctuation and flicker is: $\pm 11.49\%$

The measurement uncertainty is given with a confidence of 95%, $k=2$.

The measurement uncertainty is traceable to internal procedure TI-036.

Immunity Test

The performance criteria are based on the general criteria of the standard and derived from the product specification

Performance criterion A:

During the test no change of the luminous intensity shall be observed and the regulating control. If any, Shall operate during the test as intended.

Performance criterion B:

During the test the luminous intensity may change to any value. After the test the luminous intensity shall be restored to its initial value within 1min.

Regulating controls need not function during the test. But after the test the mode of the control shall be the same as before the test provided that during the test no mode changing commands were given.

Performance criterion C:

During and after the test any change of the luminous intensity is allowed and the lamp(s) may be extinguished. After the test, within 30 min, all functions shall return to normal if necessary by temporary interruption of the mains supply and/or operating the regulating control.

Additional requirement for lighting equipment incorporating a starting device:

After the test the lighting equipment is switched off. After half an hour it is switched on again. The lighting equipment shall start and operate as intended.

Basic EMC standard for immunity test

EN 61000-4-2: 1995/+A1:1998/+A2:2001: Electromagnetic Compatibility (EMC) – Part 4: testing and measurement techniques – section 2: electrostatic discharge immunity test

EN 61000-4-3: 2002/+A1:2002: Electromagnetic Compatibility (EMC) – Part 4: testing and measurement techniques – section 3: radiated, radio frequency, electromagnetic field immunity test

EN61000-4-4: 2004: Electromagnetic Compatibility (EMC) – Part 4: testing and measurement techniques – section 4: electric fast transient/burst immunity test

EN 61000-4-5: 1995/+A1: 2001: Electromagnetic Compatibility (EMC) – Part 4: testing and measurement techniques – section 5: surge immunity test

EN 61000-4-6: 1996/+A1:2001: Electromagnetic Compatibility (EMC) – Part 4: testing and measurement techniques – section 6: immunity to conducted disturbance, induced by radio frequency field

EN 61000-4-8: 1993/+A1:2001: Electromagnetic Compatibility (EMC) – Part 4: testing and measurement techniques – section 8: power frequency magnetic field immunity test

EN61000-4-11: 2004: Electromagnetic Compatibility (EMC) – Part 4: testing and measurement techniques – section 11: voltage dips, short interruption and voltage variations immunity test

Note: there is no magnetic sensitive component included in this EUT and magnetic field immunity test according to EN 61000-4-8 is therefore not required.

9. Electrostatic Discharge (ESD)

Test result **NA**

9.1 Severity Level and Performance Criterion

9.1.1 Test level

1a – Contact discharge		1b – Air discharge	
Level	Test voltage kV	Level	Test voltage kV
1	2	1	2
2	4	2	4
3	6	3	8
4	8	4	15
X	Special	X	Special

Notes: 1. “X” is an open level. The level has to be specified in the dedicated equipment specification. If higher voltages than those shown are specified, special test equipment may be needed.
2. The gray rows were the selected test level.

9.1.2 Performance Criterion

Performance criterion: **A:** Luminarine for emergency lighting
Performance criterion: **B:** Others

9.2 Block Diagram of Test Setup

For table-top equipment

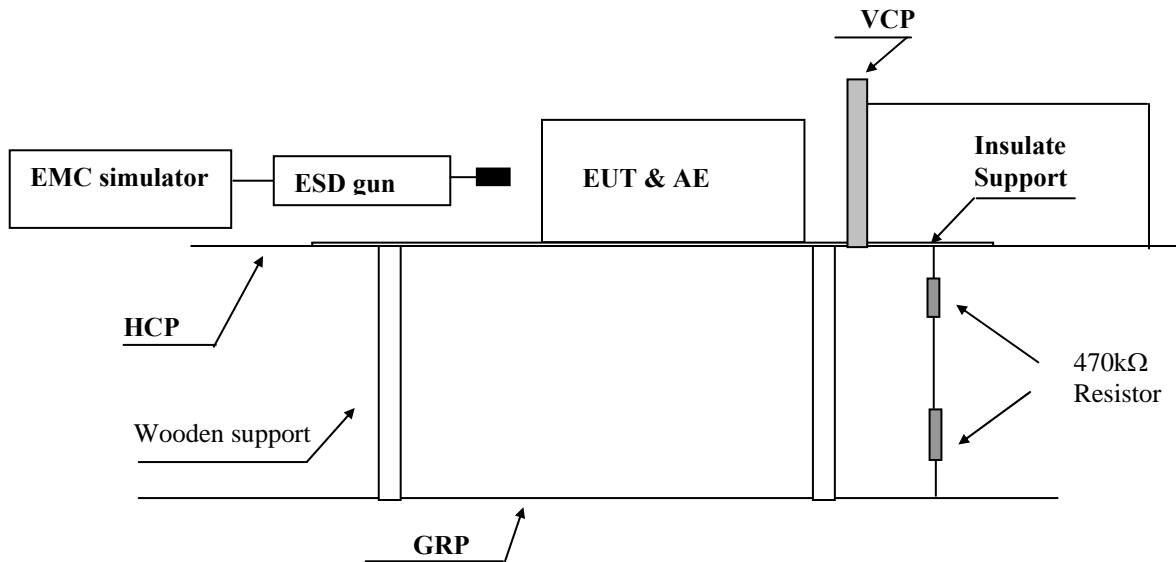

Note: HCP means Horizontal Coupling Plane
VCP means Vertical Coupling Plane
GRP means Ground Reference Plane
Wooden support is a 0.8m height table

For floor standing equipment

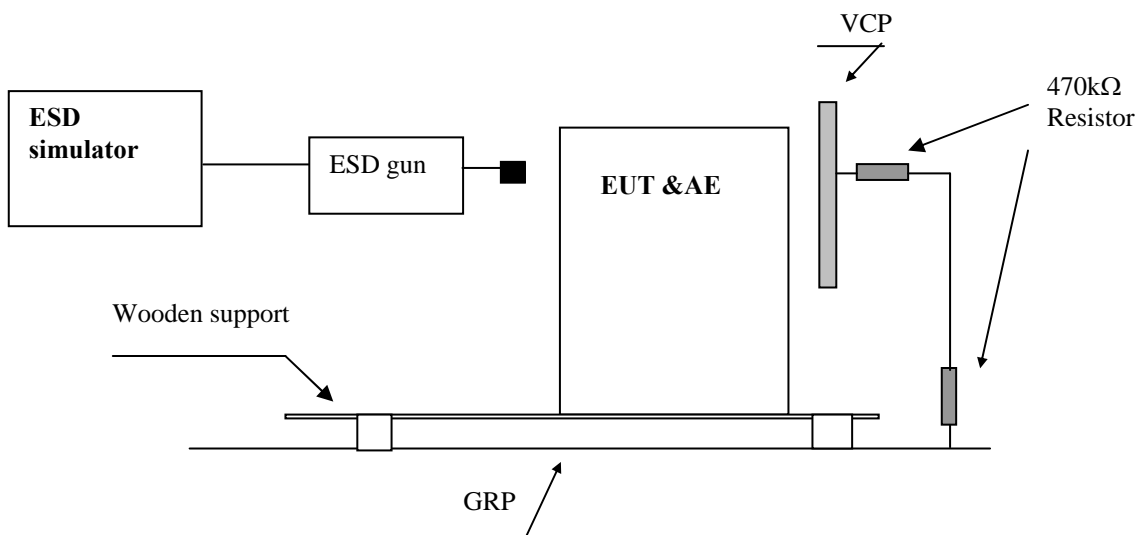

Note: VCP means Vertical Coupling Plane
GRP means Ground Reference Plane
Wooden support is a 0.1m height rack

9.3 Test Setup and Test Procedure

Measurement was performed in shielded room.

Measurement and setting of EUT was applied according to IEC61000-4-2 clause 7.1.

The test method and equipment was specified by IEC61000-4-2 with the modifications by EN61547 clause 5.2.

9.4 Test Protocol

Temperature : °C
Relative Humidity: %
Air Pressure: kPa

Direct discharges were applied at the following selected points:

Test point #	Test level [kV]	Air/Contact	Polarity (+/-)	Pass/Fail	Comment
A	2/4	Contact	+/-	Pass	all touchable screws of enclosure
B	2/4	Contact	+/-	Pass	Accessible metal parts of the EUT
C	2/4	Air	+/-	Pass	Air gap of the switch, button
D	2/4/8	Air	+/-	Pass	The air in-taking opening
E	2/4/8	Air	+/-	Pass	Slots around the EUT

Indirect contact discharges were applied to the VCP and the HCP at the following selected points:

For table top equipment

Point	Description	Point	Result
HCP f	0,1m from the front of the EUT	Edge of centre,corner on HCP	
HCP b	0,1m from the back of the EUT	Edge of centre,corner on HCP	
HCP r	0,1m from the right side of the EUT	Edge of centre,corner on HCP	
HCP l	0,1m from the left side of the EUT	Edge of centre,corner on HCP	
VCP f	0,1m from the front of the EUT	Edge of centre,corner on VCP	
VCP b	0,1m from the back of the EUT	Edge of centre,corner on VCP	
VCP r	0,1m from the right of the EUT	Edge of centre,corner on VCP	
VCP l	0,1m from the left of the EUT	Edge of centre,corner on VCP	

For floor standing equipment

Point	Description	Point	Result
VCP f	0,1m from the front of the EUT	Edge of centre,corner on VCP	-
VCP b	0,1m from the back of the EUT	Edge of centre,corner on VCP	-
VCP r	0,1m from the right of the EUT	Edge of centre,corner on VCP	-
VCP l	0,1m from the left of the EUT	Edge of centre,corner on VCP	-

Observation:

Conclusion:

9.5 Measurement Uncertainty

The measurement uncertainty describes the overall uncertainty of the given measured value during the operation of the EUT.

Measurement uncertainty of ESD test is: $\pm 6.71\%$

The measurement uncertainty is given with a confidence of 95%, $k=2$.

The measurement uncertainty is traceable to internal procedure TI-036.

9.6 Additions, Deviations and Exclusions from Standards

None

10. Electromagnetic field susceptibility

Test result **NA**

10.1 Severity Level and Performance Criterion

10.1.1 Test level

Level	Test field strength V/m
1	1
2	3
3	10
X	Special

Note: 1. X is an open test level. This level may be given in the product specification.
2. The gray row is the selected test level.

10.1.2 Performance Criterion

Performance criterion: **A**

10.2 Block diagram of test setup

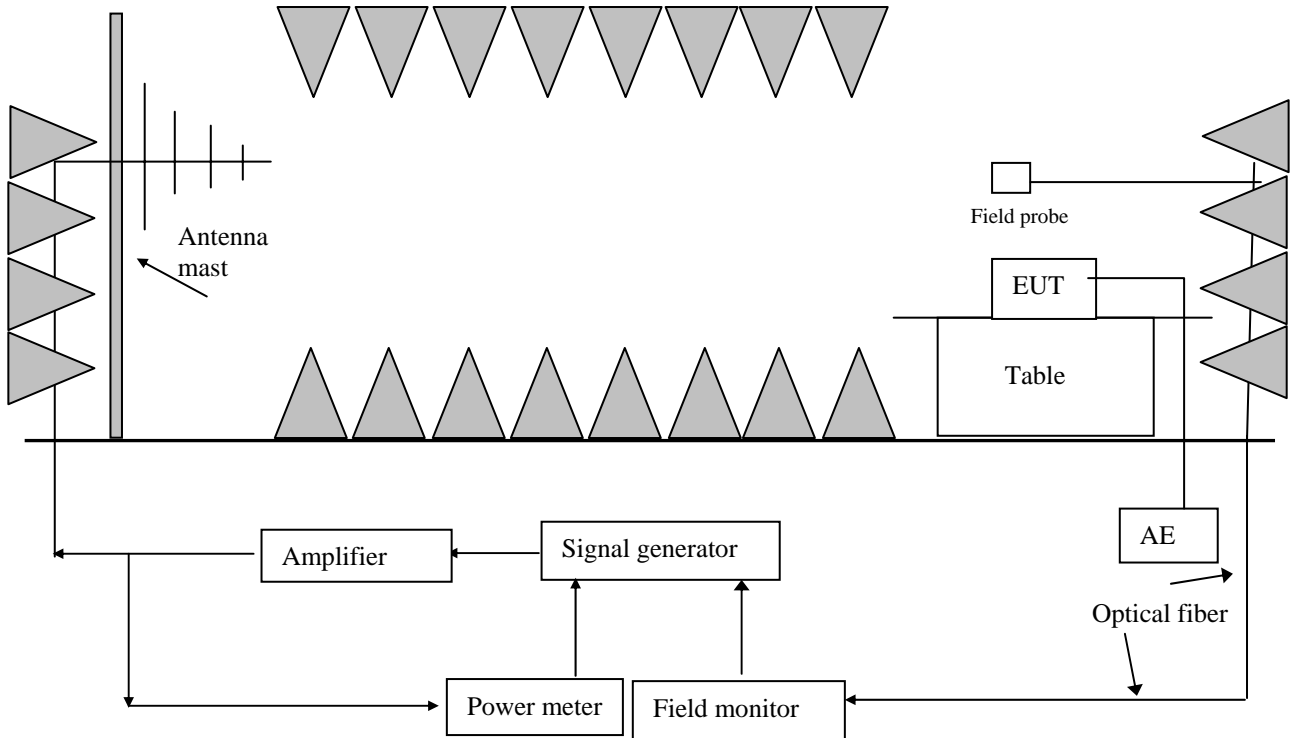

10.3 Test Setup and Test Procedure

Measurement was performed in full-anechoic chamber.
Measurement and setting of EUT was applied according to IEC61000-4-3 clause 7.
The test method and equipment was specified by IEC61000-4-3 with additions and modifications by EN61547 clause 5.3.

10.4 Test Protocol

Temperature : °C
Relative Humidity : %

Test no.:	Frequency (MHz)	Polarization	Test level V/m	Exposed location	Result	Comment
1	80-1000	H & V	3	All sides		-

Observation:

Conclusion:

10.5 Measurement Uncertainty

The measurement uncertainty describes the overall uncertainty of the given measured value during the operation of the EUT.

Measurement uncertainty of radiated susceptibility test is: $\pm 4.65\text{dB}$

The measurement uncertainty is given with a confidence of 95%, $k=2$.

The measurement uncertainty is traceable to internal procedure TI-036.

10.6 Additions, deviations and exclusions from standards

None

11. Electric Fast Transient/Burst Immunity Test

Test result **NA**

11.1 Severity Level and Performance Criterion

11.1.1 Test level

Open circuit output test voltage (+/-10%) and repetition rate of the impulses (+/- 20%)				
Level	On power supply ports PE		On I/O (input & output) signal, data and control ports	
	Voltage peak kV	Repetition rate kHz	Voltage peak kV	Repetition rate kHz
1	0.5	5	0.25	5
2	1	5	0.5	5
3	2	5	1	5
4	4	2.5	2	5
X	Special	Special	Special	Special

Notes : 1. "X" is a an open level. The level has to be specified in the dedicated equipment specification.
2. The gray rows were the selected test level.

11.1.2 Performance Criterion

Performance criterion B

11.2 Block Diagram of Test Setup

11.2.1 Block Diagram for input a.c./d.c. power line

For table-top equipment

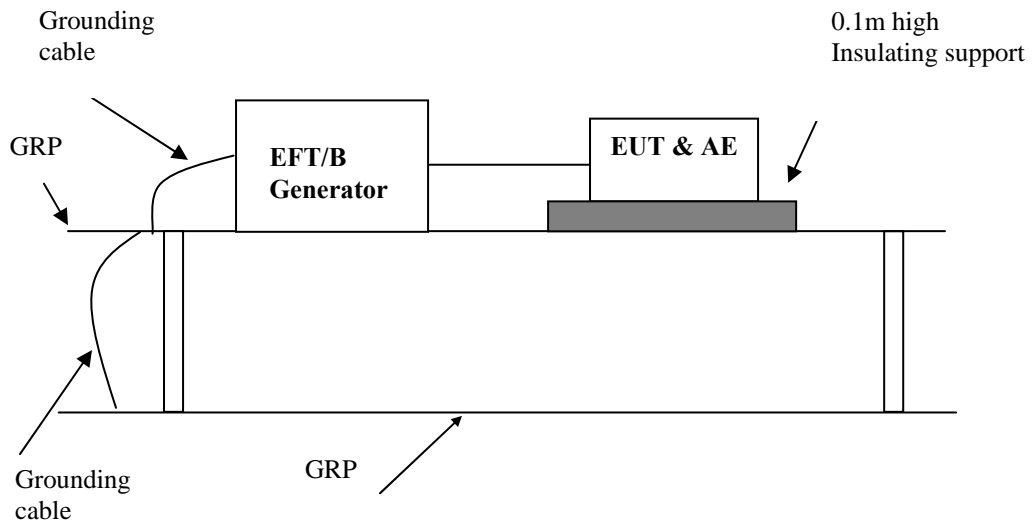

For floor standing equipment

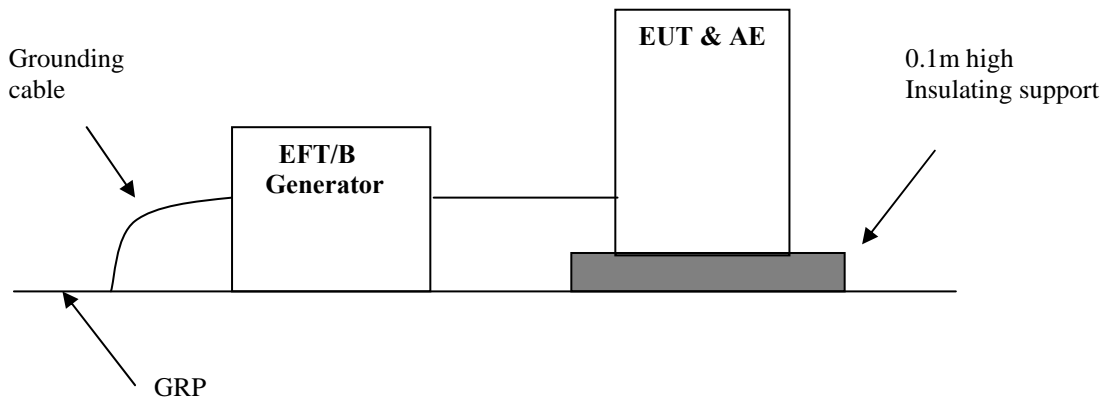

11.2.2 Block Diagram for output a.c./d.c. power line or signal/control lines

For table-top equipment

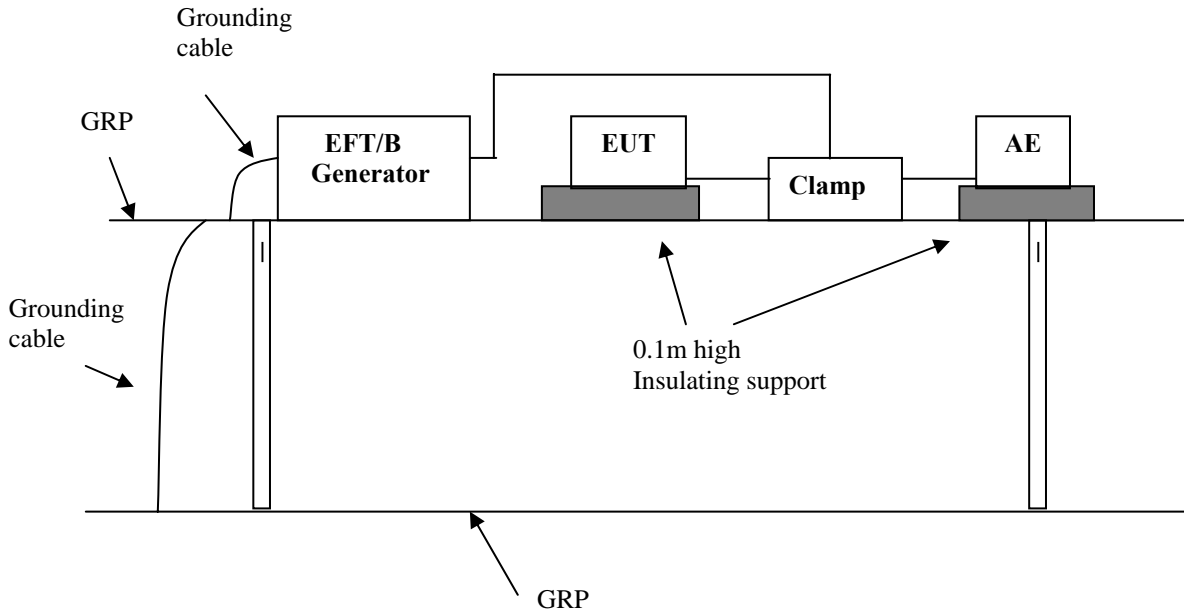

For floor standing equipment

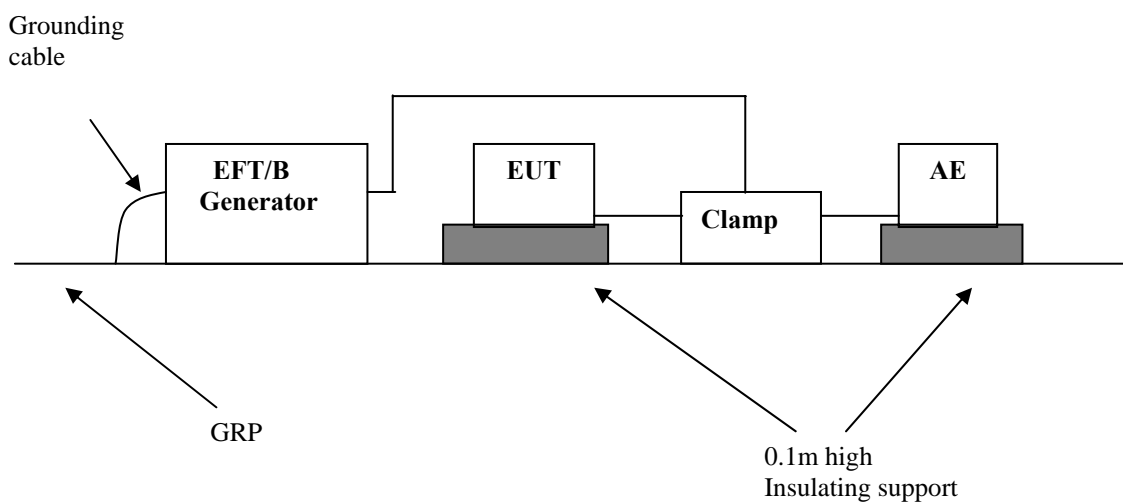

11.3 Test Setup and Test Procedure

Measurement was performed in shielded room.

Measurement and setting of EUT was applied according to IEC61000-4-4 clause 7.2.

The test method and equipment was specified by IEC61000-4-4 with additions and modifications by EN61547 clause 5.5.

11.4 Test Protocol

Temperature : °C
Relative Humidity : %

Test No. #	Level [kV]	Polarity +/-	Line for test	Pass/ Fail
1	1	+/-	a.c. Mains	
2	X	+/-	X	NA
Notes: "NA" means not applicable. "X" is for other available lines.				

Observation:

Conclusion:

11.5 Measurement Uncertainty

The measurement uncertainty describes the overall uncertainty of the given measured value during the operation of the EUT.

Measurement uncertainty of EFT test at main terminal is: $\pm 33.19\%$

Measurement uncertainty of EFT test at signal/telecom terminal is: $\pm 33.24\%$

The measurement uncertainty is given with a confidence of 95%, $k=2$.

The measurement uncertainty is traceable to internal procedure TI-036.

11.6 Additions, Deviations and Exclusions from Standards

None

12. Surge Immunity Test

Test result **NA**

12.1 Severity Level and Performance Criterion

12.1.1 Test level

Level	Open-circuit test voltage +/-10% kV
1	0.5
2	1.0
3	2.0
4	4.0
X*	Special

Notes: 1."X" is an open class. This level can be specified in the product Specification
 2. The gray rows are the selected level. Class 2 is applied to Phase to Phase (L-N)
 Class 3 is applied to Phase to PE (L-PE),(N-PE)

12.1.2 Performance Criterion

Performance criterion **B**: Regulating device for ballast or convertor and luminarire for emergency lighting
 Performance criterion **C**: Others

12.2 Block Diagram of Test Setup

12.2.1 Block Diagram for input a.c. power line

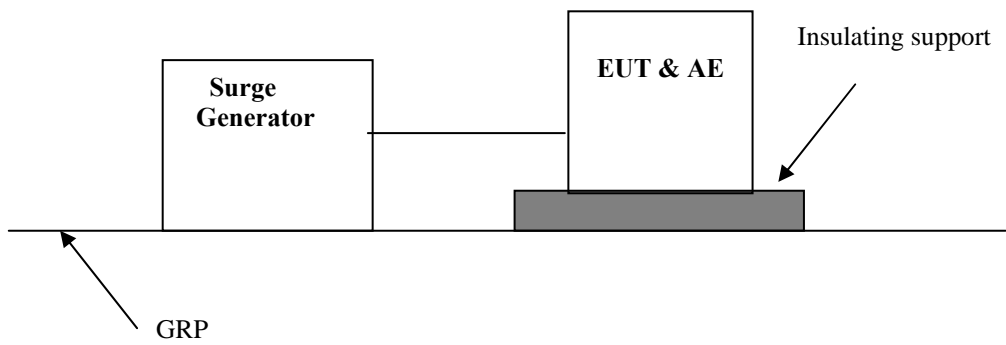

12.3 Test Setup and Test Procedure

Measurement was performed in shielded room.

Measurement and setting of EUT was applied according to IEC61000-4-5 clause 7.

The test method and equipment was specified by IEC61000-4-5 with modifications by EN61547 clause 5.7.

12.4 Test Protocol

Temperature : °C
Relative Humidity : %

Test No. #	Level [kV]	Polarity +/-	Line for test	Pass/ Fail
1	0.5 / 1	+/-	a.c. Mains (line to line)	
2	1 / 2	+/-	a.c. Mains (line to earth)	
3	X	+/-	X	
Notes: "NA" means not applicable. "X" is for other available lines For Luminaries and independent auxiliaries, which input power is larger than 25W, the test level will be the second one.				

Observation:

Conclusion:

12.5 Measurement Uncertainty

The measurement uncertainty describes the overall uncertainty of the given measured value during the operation of the EUT.

Measurement uncertainty of surge test at main terminal is: $\pm 18.80\%$

The measurement uncertainty is given with a confidence of 95%, $k=2$.

The measurement uncertainty is traceable to internal procedure TI-036.

12.6 Additions, Deviations and Exclusions from Standards

None

13. Immunity to Conducted Disturbances, Induced by Radio-frequency Fields

Test result **NA**

13.1 Severity Level and Performance Criterion

13.1.1 Test level

Frequency range 150kHz – 80MHz		
Level	Voltage level (e.m.f.)	
	U0 [dB(uV)]	U0 (V)
1	120	1
2	130	3
3	140	10
X	Special	Special

Notes: 1. "X" is an open level
2. The gray row is the selected test level.

13.1.2 Performance Criterion

Performance criterion **A**

13.2 Block Diagram of Test Setup

13.2.1 Block Diagram for a.c./d.c input power line

Block Diagram for a.c./d.c input power line

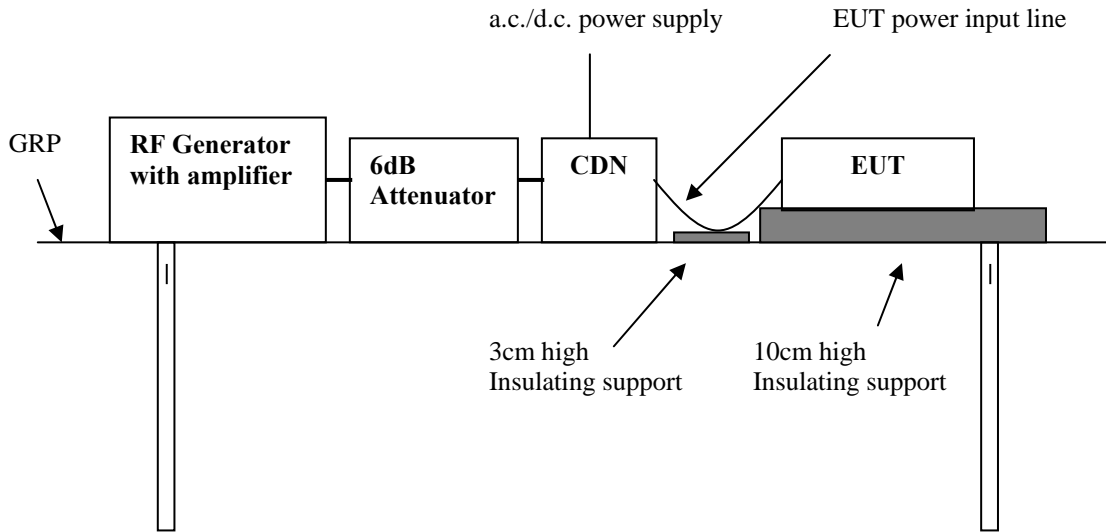

13.2.2 Block Diagram for output a.c./d.c. power line or signal/control lines

Unshielded line

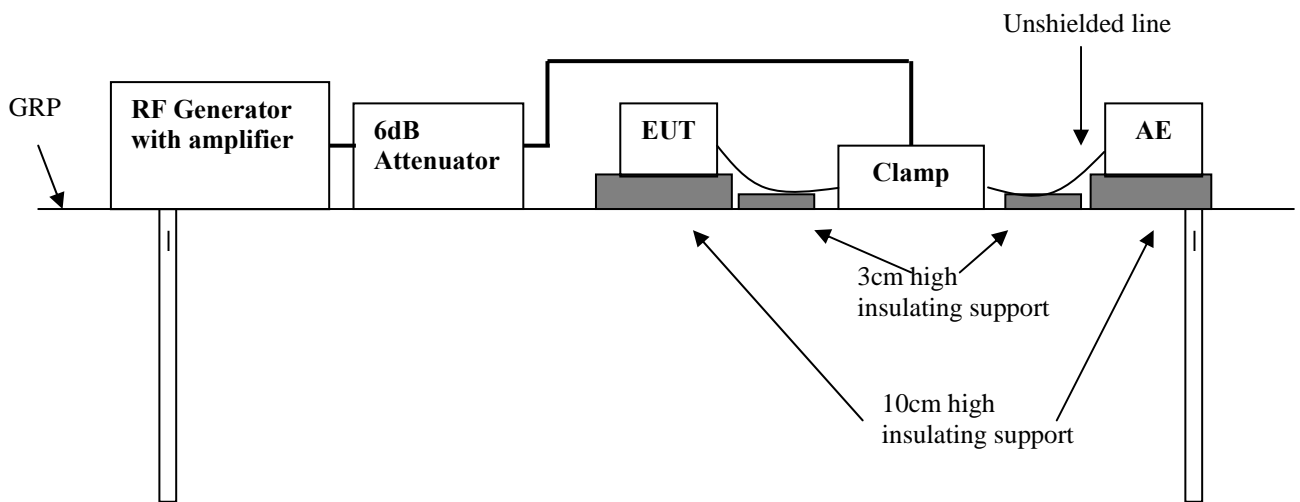

Shielded line

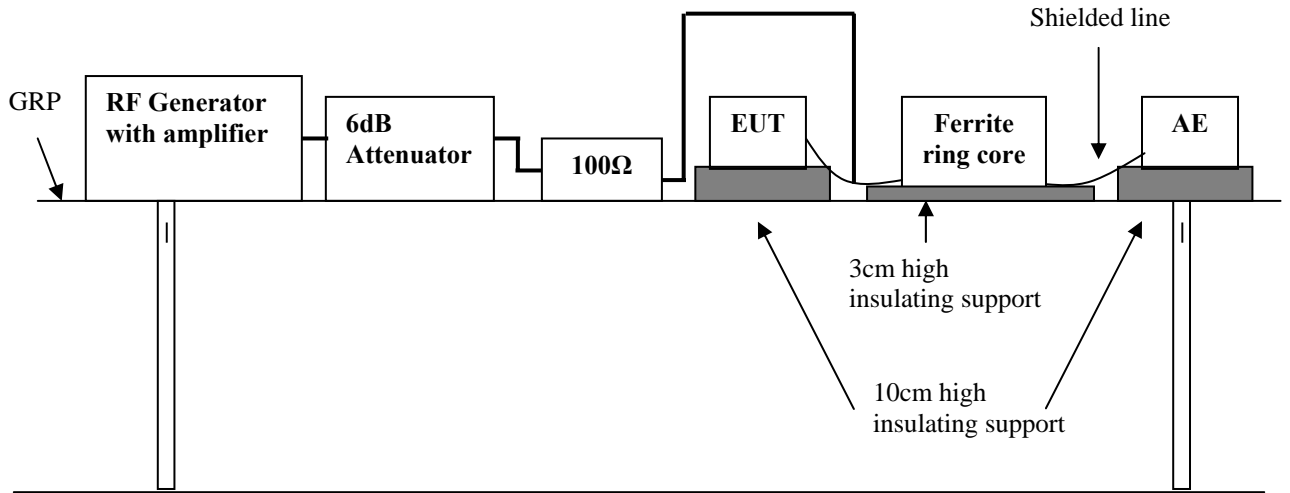

13.3 Test Setup and Test Procedure

Measurement was performed in shielded room.

Measurement and setting of EUT was applied according to IEC61000-4-6 clause 7.

The test method and equipment was specified by IEC61000-4-6 with additions and modifications by EN61547 clause 5.6.

13.4 Test Protocol

Temperature : °C
Relative Humidity : %

Test No.	Frequency (MHz)	Level V (e.m.f.)	Amplitude modulation	Injected point	Result
1	0.15~80	3	1kHz 80%	a.c. Mains	
2	0.15~80	1	1kHz 80%	Signal lines	

Observation:

Conclusion:

13.5 Measurement Uncertainty

The measurement uncertainty describes the overall uncertainty of the given measured value during the operation of the EUT.

Measurement uncertainty of injected current test at main terminal is $\pm 3.66\text{dB}$.

Measurement uncertainty of injected current test at unshielded signal terminal is $\pm 3.21\text{dB}$.

Measurement uncertainty of injected current test at shielded signal terminal is under consideration.

The measurement uncertainty is given with a confidence of 95%, $k=2$.

The measurement uncertainty is traceable to internal procedure TI-036.

13.6 Additions, Deviations and Exclusions from Standards

None

14. Voltage Dips, Short Interruptions and Voltage Variations Immunity Test

Test result **NA**

14.1 Severity Level and Performance Criterion

14.1.1 Test level

Test level % UT	Voltage dip and short interruptions % UT	Duration (in period)
0	100	0.5*
		250
40	60	25
		10
70	30	0.5
		10
		X **

Notes:

1. “*” for 0.5 period, the test shall be made in positive and negative polarity, i.e. starting at 0° and 180°, respectively
2. “**” means “x” is an open duration. This duration can be given in the product specification. Utilities in Europe have measured dips and short interruptions of duration between ½ a period and 3000 periods, but duration less than 50 periods are most common.
3. If the EUT is tested for voltage dips of 100%, it is generally unnecessary to test for other levels for the same durations. However, for some cases (safeguard systems or electro-mechanical devices) it is not true. The product specification or product committee shall give an indication of the applicability of this note.
4. The gray rows are selected test level.

14.1.2 Performance Criterion

Performance criterion C at the test level 30%,
Performance criterion B at the test level 100%.

14.2 Block diagram of test setup

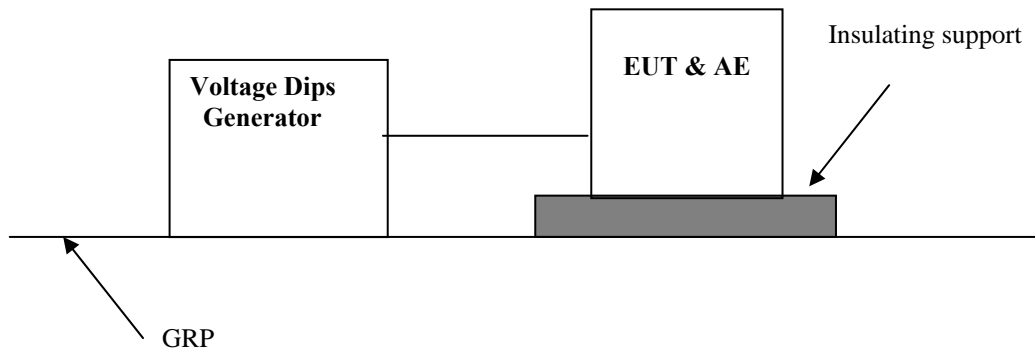

14.3 Test Setup and Test Procedure

Measurement was performed in shielded room.

Measurement and setting of EUT was applied according to IEC61000-4-11 clause 7.

The test method and equipment was specified by IEC61000-4-11 with additions and modifications by EN61547 clause 5.8.

14.4 Test Protocol

Temperature : °C
Relative Humidity : %

Test no.	Test level % UT	Voltage dip and short interruptions % UT	Duration (in periods)	Pass/ Fail	Comment
1	70	30%	10		-
2	0	100% pos half cycle	0,5		-
3	0	100% neg half cycle	0,5		-

Observation:

Conclusion:

14.5 Measurement Uncertainty

The measurement uncertainty describes the overall uncertainty of the given measured value during the operation of the EUT.

Measurement uncertainty of voltage dips and interruption test is: $\pm 3.37\%$

The measurement uncertainty is given with a confidence of 95%, $k=2$.

The measurement uncertainty is traceable to internal procedure TI-036.

14.6 Additions, deviations and exclusions from standards

None

Appendix I: Photograph of Test setup

Conducted emission



Harmonic & Flicker Test

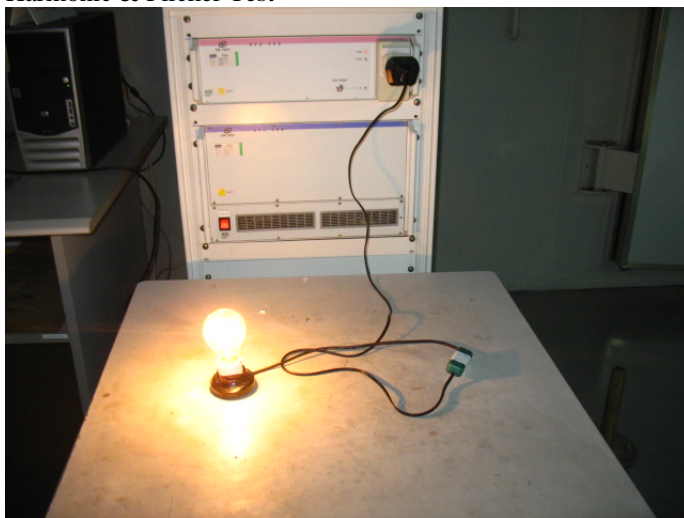

Appendix II: Photograph of EUT



